



创

书

号 s201910536005

名 基于 优化 3D 印 凝土 受

力

人 何 18774889601

在 土

号 201608020628 专业 1601

友

E-mail 1249021180@qq.com

2019 4 30

2019 5 2020 5



一、基 况

	●					

Engineering Str ct re Structural Safet ASCE Jo rnal of
Str ct ral Engineering

Yo bao Jiang*, Hao Zho , Michael Beer, Lei Wang, Jianren
Zhang, Linjie Zhao. Stiffness of Load Resistance Design
Factors for RC Columns Under Wind-Induced Combination
Considering Random Eccentricity. Journal of Structural Engineering
ASCE, 2017, 143(4): 04016221

2) Yo bao Jiang*, Linjie Zhao, Michael Beer, Gardo
Patelli, Matteo Brogioni, Lu-Ming Hu, Jianren Zhang. Multiple
response surface method with a new classification of samples for
structural failure probability estimation. Structural Safety, 2017, 64
(2017):87-97

3) Yo bao Jiang*, Qing Cao, Han Jiang, Gao Jianren.
Stiffness reduction of precast cable arch structure under
efficient method. Advances in Structural Engineering, 2017, 11
1927- 1939.

4) Yo bao Jiang*, Gohem Sanjiv, Michael Beer,
Jianren Zhang. Nonlinear moment-rotation relationship for
reliability analysis of RC frame columns. International
Engineering Str ct re 15-98(2015) :74-80.

5) Yo bao Jiang*, L. Gao, Jianren Zhang, Jianren
Zhang. An efficient method for generating random vector
and its application in structural failure probability estimation. J
Safet , 2015, 54(2015) : 19.

6) Yo bao Jiang*, Weijun Wang. An approach based on
theorem of total probability for reliability analysis of RC columns
with random eccentricity. Str ct ral Safet , 2013, 41(1):37-46.

7) Lei Wang*, Yi Jiang, Qing Cao, Yo bao Jiang, X h i
Zhang. Effect of corrosion-induced degradation of the bond between strand
and concrete[J]. Construction Building Materials, 2017, 153:
598-606.

8) Cai Jiang o*; Zhong Qianqian, Yo bao Jiang, Yi Jiang, Feng
Jian; Deng Xiao ei. Nonlinear stability analysis of a ball
retractable hybrid grid shell in the closed position. Steel and
Composite Str ct re 2017, 24(3): 287-296.

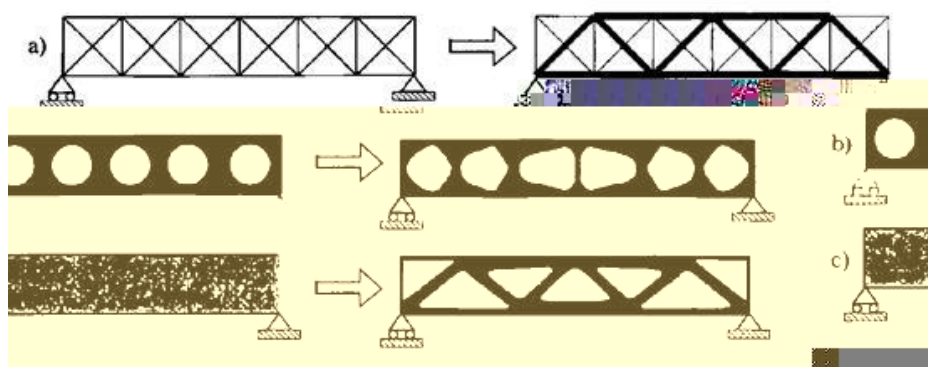

[1]

[2]

[3]

[4]S. Lim, R.A. B s el, T.T. Le, S.A. A stin, A.G. Gibb, T. Thorpe. De elopments in construction technology and human factors in construction. A tom, Constr. 21(2012) 262–268.

[5]A. Tiba t, D. P. Intoperabilit re t a tom human factors systems in construction. ell. Man f. (2014)

- [6]E. Lloret, A.R. Shahab, M. Lins, R.J. Flott, F. Gramaio, M. Kohler, S. Langenberg. Complete concrete structure using additive casting techniques with digital fabrication, *Computational Aided Design* 60 (2017) 49.
- [7]Domenico Asprone, Costantino Menna, Frank P. Bos, et al. Rethinking reinforcement for digital fabrication with concrete[J]. *Cement and Concrete Research*, 2018, 112(1): 111-121.
- [8] C. Scott, Chinese Construction Company 3D Prints an Entire Two-Storey House in 45 Days, *3dprint.com*, 2017-11-20, <https://3dprint.com/138664/shanghai-3d-print-house/> (accessed March 20, 2017).
- [9]Perrot A, Rangeard D, Pierre A. Mechanical behavior of cement-based materials used for 3D printing: a review[J]. *Materials & Structures* 2019(4):1213-1220
- [10]
- [11]Ma G, Li Z, Wang L. Printing properties of cementitious material containing copper tailings for extrusion-based 3D printing[J]. *Construction & Building Materials*, 2018, 162:613-627.
- [12]
- [13]Biranchi Panda, S. Anand Chandra Paul, Ming-Jen Tan. Anisotropic mechanical performance of 3D printed fiber reinforced structural construction material[J]. *Materials Letters*.2017,209(1):146-149.
- [14]Lim J H, Panda B, Pham V C. Improving flexural characteristics of 3D printed geopolymers composites with in-process steel cable reinforcement[J]. *Construction & Building Materials*, 2018, 178:32-41.
- [15]Gong Mo, Zhijian Li, Li Wang, Gang Bai. Micro-cable reinforced geopolymer composite for extrusion-based 3D printing[J]. *Materials Letters* 2019,235(1):144-147.
- [16]Asprone D, Ruchini F, Menna C, et al. 3D printing of reinforced concrete elements: Technology and design approach[J]. *Construction & Building Materials*, 2018, 165:218-231.
- [17]Wang P, Wang J, Wang L. A critical review of the state of 3D printing in the construction industry[J]. *Automation in Construction* 2016, 68:21-31.
- [18]
- [19]Halding P S, Halding K D, Schmidt J W, et al. Full-scale load tests of Pearl-Chain arches[J]. *Engineering Structures* 2017, 131:101-114.
- [20]
- [21]

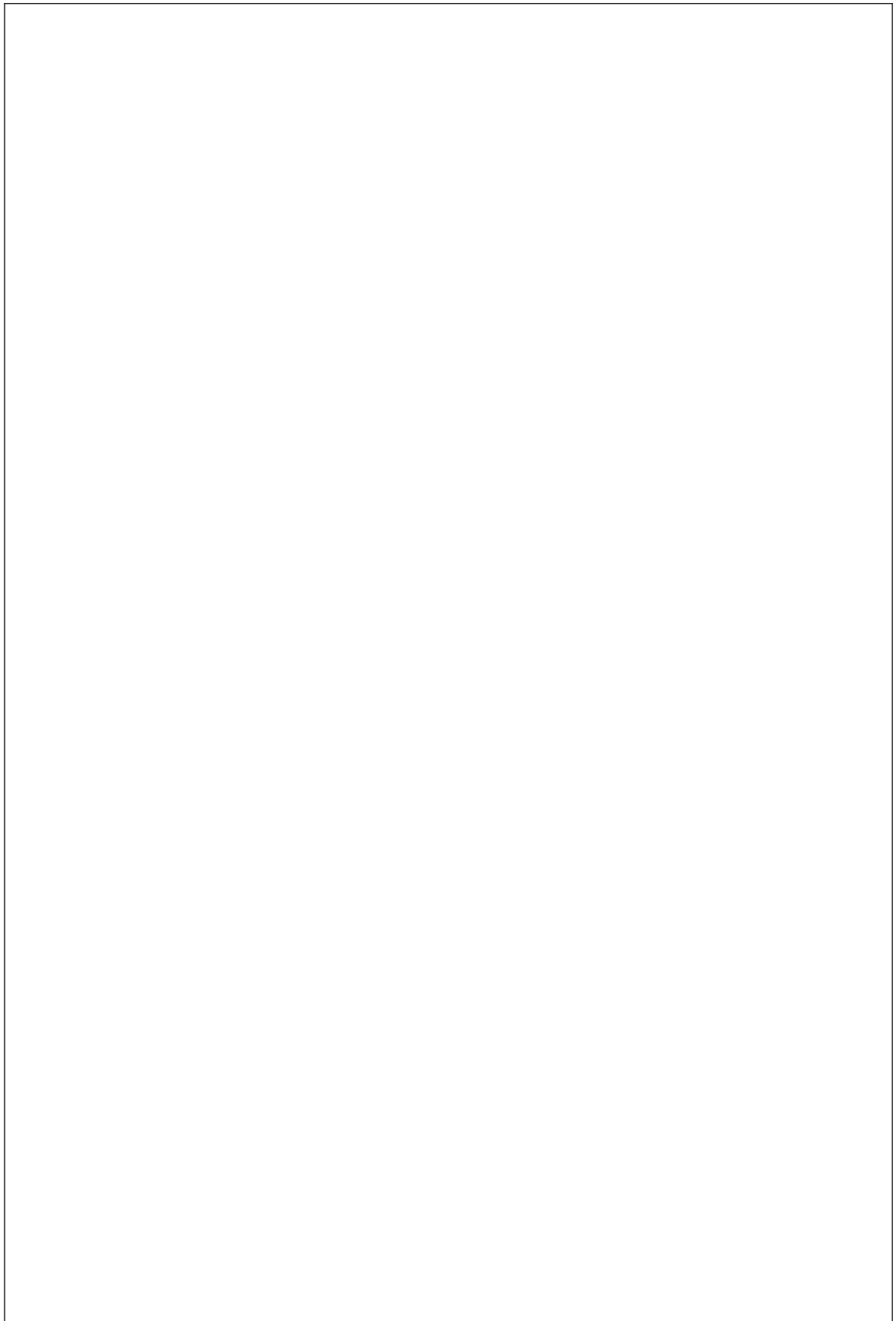

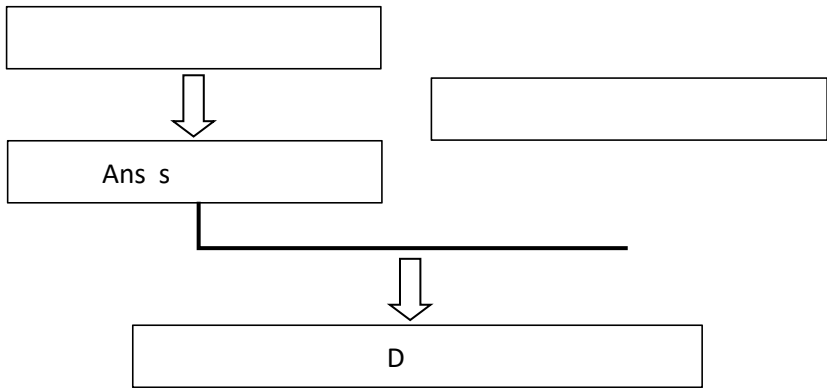
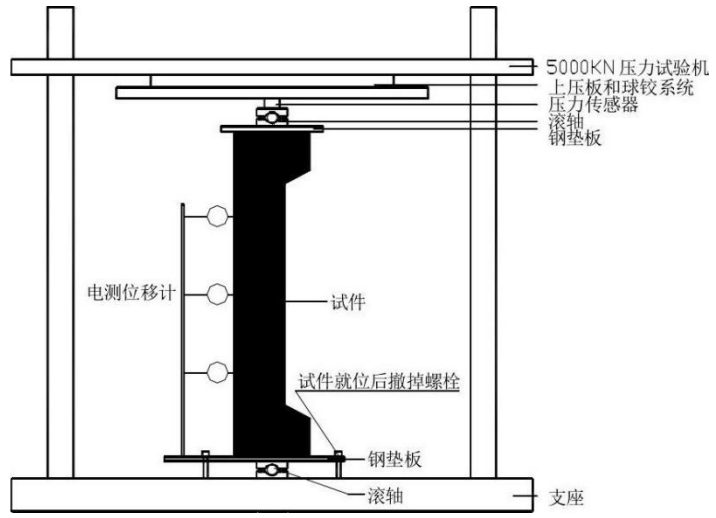

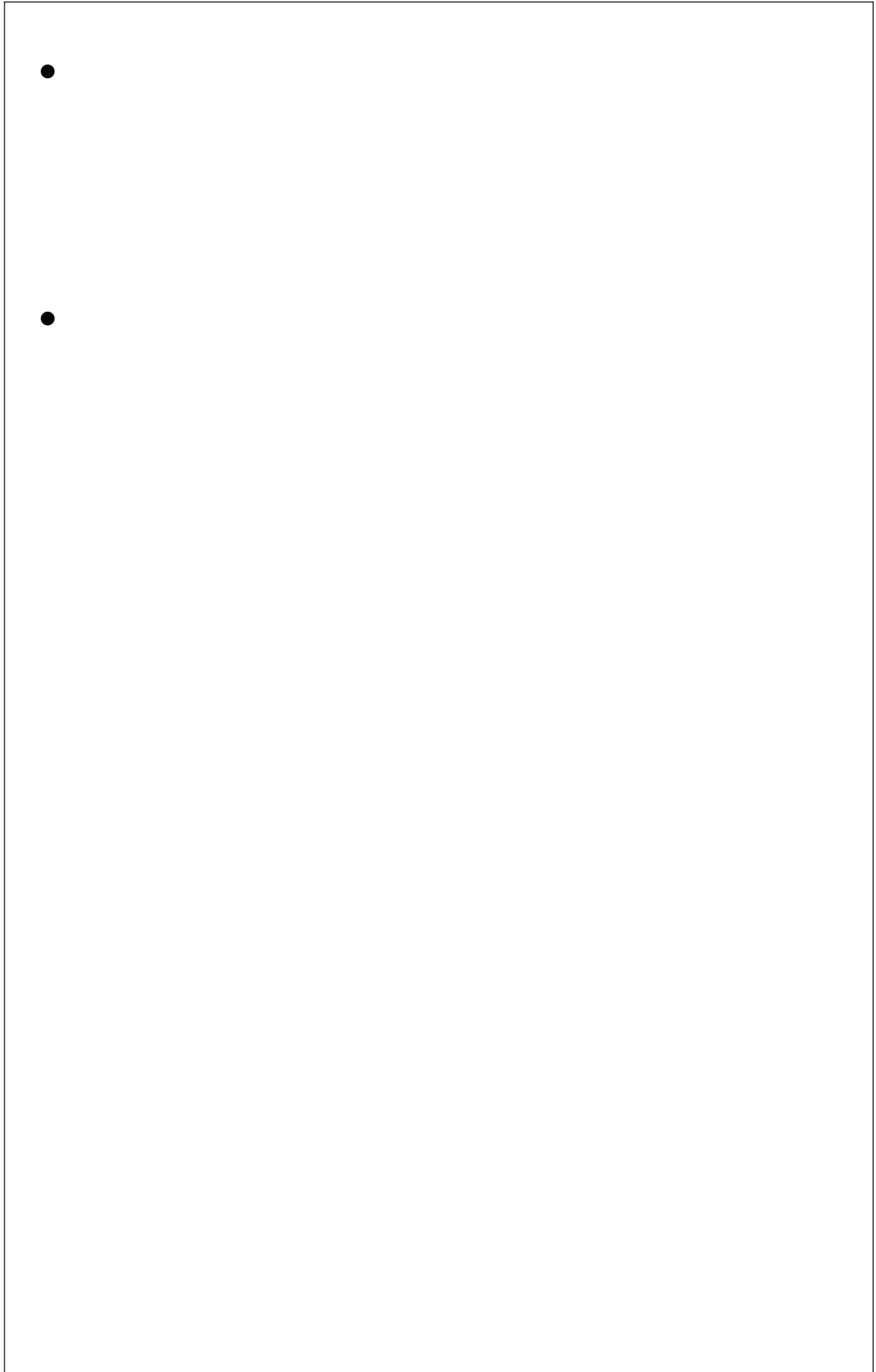

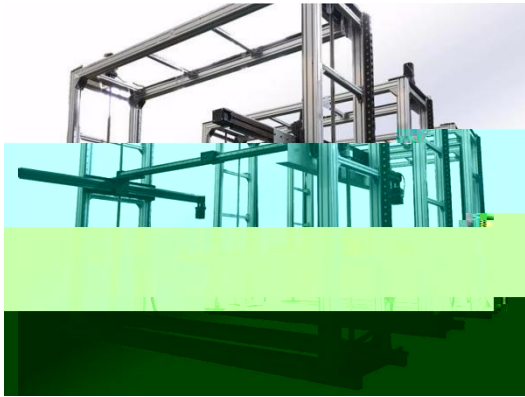

七、 创 创业 划

负责人（签章）：
年 月 日